



Series PP4QQ/4



SET-2

प्रश्न-पत्र कोड
Q.P. Code 57/4/2

रोल नं.

Roll No.

--	--	--	--	--	--	--	--	--	--

परीक्षार्थी प्रश्न-पत्र कोड को उत्तर-पुस्तिका के मुख-पृष्ठ पर अवश्य लिखें।

Candidates must write the Q.P. Code on the title page of the answer-book.

नोट

- (I) कृपया जाँच कर लें कि इस प्रश्न-पत्र में मुद्रित पृष्ठ 23 हैं।
- (II) कृपया जाँच कर लें कि इस प्रश्न-पत्र में 33 प्रश्न हैं।
- (III) प्रश्न-पत्र में दाहिने हाथ की ओर दिए गए प्रश्न-पत्र कोड को परीक्षार्थी उत्तर-पुस्तिका के मुख-पृष्ठ पर लिखें।
- (IV) कृपया प्रश्न का उत्तर लिखना शुरू करने से पहले, उत्तर-पुस्तिका में प्रश्न का क्रमांक अवश्य लिखें।
- (V) इस प्रश्न-पत्र को पढ़ने के लिए 15 मिनट का समय दिया गया है। प्रश्न-पत्र का वितरण पूर्वाह्न में 10.15 बजे किया जाएगा। 10.15 बजे से 10.30 बजे तक परीक्षार्थी केवल प्रश्न-पत्र को पढ़ेंगे और इस अवधि के दौरान वे उत्तर-पुस्तिका पर कोई उत्तर नहीं लिखेंगे।



NOTE

- (I) Please check that this question paper contains 23 printed pages.
- (II) Please check that this question paper contains 33 questions.
- (III) Q.P. Code given on the right hand side of the question paper should be written on the title page of the answer-book by the candidate.
- (IV) Please write down the serial number of the question in the answer-book before attempting it.
- (V) 15 minute time has been allotted to read this question paper. The question paper will be distributed at 10.15 a.m. From 10.15 a.m. to 10.30 a.m., the candidates will read the question paper only and will not write any answer on the answer-book during this period.

जीव विज्ञान (सैद्धान्तिक) BIOLOGY (Theory)

निर्धारित समय : 3 घण्टे

Time allowed : 3 hours

अधिकतम अंक : 70

Maximum Marks : 70

57/4/2/21

228 B

1



P.T.O.





सामान्य निर्देश :

निम्नलिखित निर्देशों को ध्यानपूर्वक पढ़िए और उनका पालन कीजिए :

- (i) इस प्रश्नपत्र में 33 प्रश्न हैं। सभी प्रश्न अनिवार्य हैं।
- (ii) प्रश्नपत्र पाँच खण्डों में विभाजित है – खण्ड क, ख, ग, घ तथा ङ।
- (iii) खण्ड क – प्रश्न संख्या 1 से 16 तक बहुविकल्पीय प्रकार के प्रश्न हैं। प्रत्येक प्रश्न 1 अंक का है।
- (iv) खण्ड ख – प्रश्न संख्या 17 से 21 तक अति लघु उत्तरीय प्रकार के प्रश्न हैं। प्रत्येक प्रश्न 2 अंकों का है।
- (v) खण्ड ग – प्रश्न संख्या 22 से 28 तक लघु उत्तरीय प्रकार के प्रश्न हैं। प्रत्येक प्रश्न 3 अंकों का है।
- (vi) खण्ड घ – प्रश्न संख्या 29 तथा 30 केस आधारित प्रश्न हैं। प्रत्येक प्रश्न 4 अंकों का है। इन उपप्रश्नों में से एक उपप्रश्न में आंतरिक विकल्प का चयन दिया गया है।
- (vii) खण्ड ङ – प्रश्न संख्या 31 से 33 तक दीर्घ-उत्तरीय प्रकार के प्रश्न हैं। प्रत्येक प्रश्न 5 अंकों का है।
- (viii) प्रश्नपत्र में समग्र विकल्प नहीं दिया गया है। यद्यपि, खण्ड ख, खण्ड ग तथा खण्ड घ में आंतरिक विकल्प का प्रावधान दिया गया है। परीक्षार्थी को इन प्रश्नों में से किसी एक प्रश्न का उत्तर लिखना है।
- (ix) ध्यान दें कि दृष्टिबाधित परीक्षार्थियों के लिए अलग प्रश्नपत्र है।
- (x) जहाँ कहीं आवश्यक हो, साफ-सुथरे और उचित रूप से नामांकित चित्र बनाए जाने चाहिए।





General Instructions :

Read the following instructions carefully and follow them :

- (i) *This question paper contains 33 questions. All questions are compulsory.*
- (ii) *Question paper is divided into FIVE sections – Section A, B, C, D and E.*
- (iii) *Section A – question number 1 to 16 are multiple choice type questions. Each question carries 1 mark.*
- (iv) *Section B – question number 17 to 21 are very short answer type questions. Each question carries 2 marks.*
- (v) *Section C – question number 22 to 28 are short answer type questions. Each question carries 3 marks.*
- (vi) *Section D – question number 29 and 30 are case-based questions. Each question carries 4 marks. Each question has subparts with internal choice in one of the subparts.*
- (vii) *Section E – question number 31 to 33 are long answer type questions. Each question carries 5 marks.*
- (viii) *There is no overall choice. However, an internal choice has been provided in section B, C and D of question paper. A candidate has to write answer for only one of the alternatives in such questions.*
- (ix) *Kindly note that there is a separate question paper for Visually Impaired candidates.*
- (x) *Wherever necessary, neat and properly labelled diagrams should be drawn.*





प्रश्न संख्या 1 से 16 तक बहुविकल्पीय प्रकार के 1 अंक के प्रश्न हैं।

1. एक आवृतबीजी के निषेचित बीजाण्ड की कोशिकाओं में n , $2n$ तथा $3n$ गुणसूत्रता क्रमशः इन कोशिकाओं में पाई जाती है। 1
(A) प्रतिव्यासांत, युग्मज तथा भ्रूणपोष
(B) युग्मज, बीजाण्डकाय तथा भ्रूणपोष
(C) भ्रूणपोष, बीजाण्डकाय तथा युग्मज
(D) प्रतिव्यासांत, सहाय कोशिका तथा अध्यावरण
2. मानव में टर्नर सिंड्रोम होने का कारण है 1
(A) असुगुणिता (एन्युप्लोइडी) (B) सुगुणिता (यूप्लोइडी)
(C) बहुगुणिता (पॉलिप्लोइडी) (D) अलिंगी विकार
3. मूल सिद्धांत (सेंट्रल डोग्मा) के निम्न आरेख में 'P', 'Q' तथा 'R' को निम्नलिखित में से किस विकल्प में सही ढंग से अभिचित्रित किया गया है ? 1

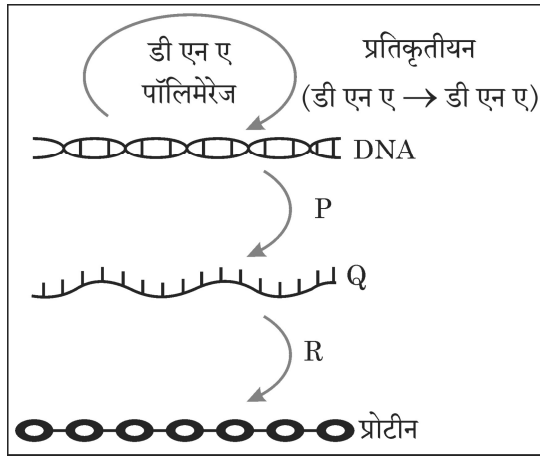

- (A) P – प्रतिकृतियन, Q – rआरएनए, R – अनुलेखन
- (B) P – रूपांतरण, Q – mआरएनए, R – अनुलेखन
- (C) P – प्रतिकृतियन, Q – mआरएनए, R – रूपांतरण
- (D) P – अनुलेखन, Q – mआरएनए, R – रूपांतरण





SECTION – A

16 × 1 = 16

Question Nos. 1 to 16 are Multiple Choice type Questions, carrying 1 mark each.

1. In a fertilized ovule of an angiosperm, the cells in which n , $2n$ and $3n$ conditions respectively occur are : 1
(A) antipodal, zygote and endosperm
(B) zygote, nucellus and endosperm
(C) endosperm, nucellus and zygote
(D) antipodals, synergids and integuments
2. Turner's syndrome in humans occurs due to 1
(A) Aneuploidy (B) Euploidy
(C) Polyploidy (D) Autosomal abnormality
3. Which of the options has correct identification of 'P', 'Q' and 'R' in the illustration of 'Central Dogma' given below ? 1

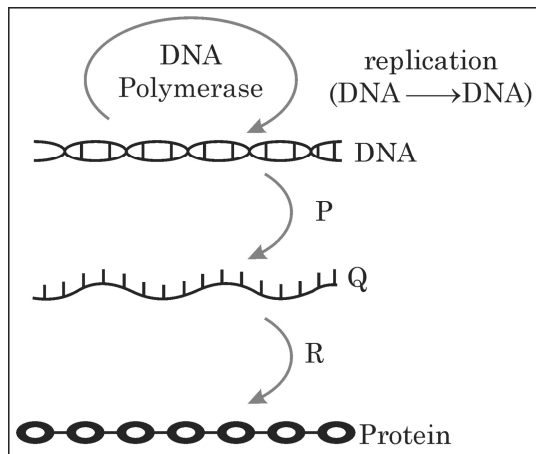

- (A) P – Replication, Q – rRNA, R – Transcription
- (B) P – Translation, Q – mRNA, R – Transcription
- (C) P – Replication, Q – mRNA, R – Translation
- (D) P – Transcription, Q – mRNA, R – Translation

57/4/2/21

5



P.T.O.



4. नीचे दिए चित्र में दर्शाए गए आवृतबीजी की लघुबीजाणुधानी की अनुप्रस्थ-काट का अध्ययन कीजिए : 1

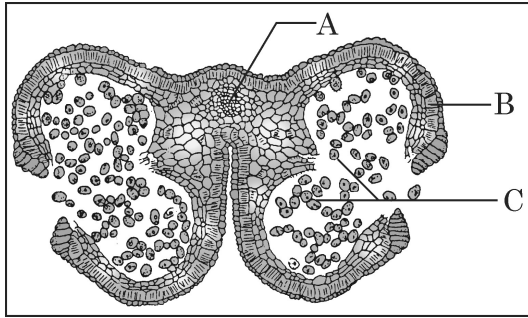

उस विकल्प को चुनिए जिसमें 'A', 'B' तथा 'C' की सही पहचान की गई है।

- (A) A – संयोजी, B – अन्तस्थीसियम, C – परागकण
(B) A – अन्तस्थीसियम, B – संयोजी, C – परागकण
(C) A – परागकण, B – संयोजी, C – अन्तस्थीसियम
(D) A – अन्तस्थीसियम, B – परागकण, C – संयोजी
5. उस विकल्प को चुनिए जो नीचे दिए गए चित्र में मानव मादा (स्त्री) के जनन तंत्र में अंडाणु, तूतक (मोरूला) तथा कोरकपुटी की सही पहचान दर्शाता है : 1

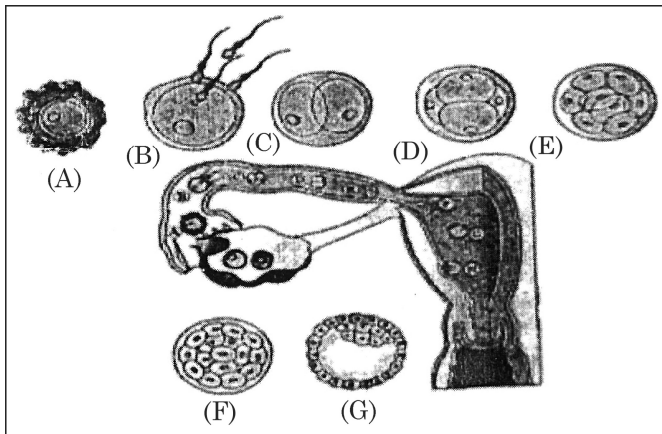

- (A) अंडाणु-B, मोरूला-D, कोरकपुटी-F
(B) अंडाणु-A, मोरूला-B, कोरकपुटी-G
(C) अंडाणु-A, मोरूला-E, कोरकपुटी-G
(D) अंडाणु-B, मोरूला-D, कोरकपुटी-G





4. Study the following diagram of Transverse Section of a young anther of an angiosperm : 1

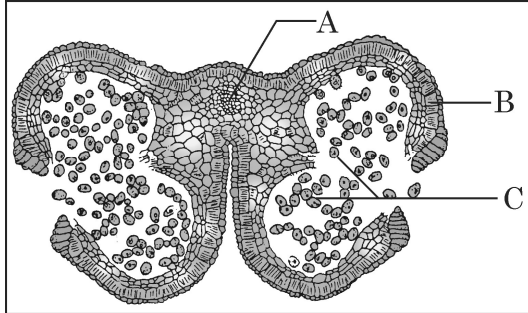

Select the option where parts 'A', 'B' and 'C' are correctly identified.

- (A) A – Connective, B – Endothecium, C – Pollen grain.
(B) A – Endothecium, B – Connective, C – Pollen grain.
(C) A – Pollen grain, B – Connective, C – Endothecium.
(D) A – Endothecium, B – Pollen grain, C – Connective.
5. Select the option that gives the correct identification of ovum, morula and blastocyst in a human female reproduction system as shown in the following diagram : 1

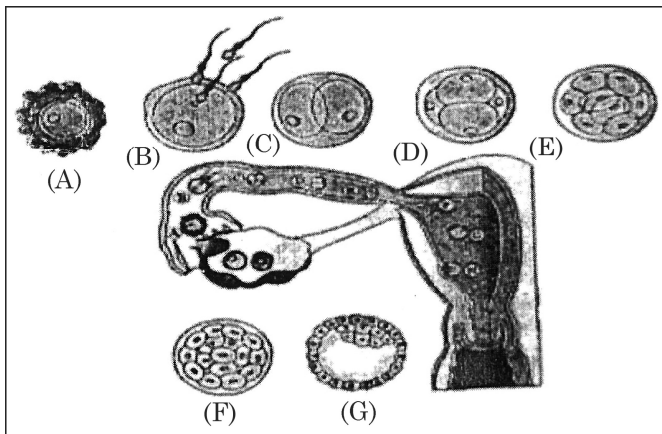

- (A) Ovum – B, Morula – D, Blastocyst – F
(B) Ovum – A, Morula – B, Blastocyst – G
(C) Ovum – A, Morula – E, Blastocyst – G
(D) Ovum – B, Morula – D, Blastocyst – G





6. नीचे दी गई तालिका का अध्ययन कीजिए :

1

गर्भनिरोधक साधन/गर्भनिरोधी विधि	कार्य का तरीका
A. गोली (पिल)	I. शुक्राणु को गर्भाशय ग्रीवा तक पहुँचने से रोकना
B. कंडोम	II. अंतरोपण को रोकना
C. शुक्रवाहक उच्छेदन (वेसेक्टोमी)	III. अंडोत्सर्ग का संदमन
D. कॉपर-टी	IV. वीर्य में शुक्राणु नहीं होते

उस विकल्प का चयन कीजिए जिसमें गर्भनिरोधक साधन/गर्भनिरोधी विधि का उसके कार्य के तरीके से सही मिलान किया गया है :

- (A) A – III, B – II, C – I, D – IV (B) A – II, B – III, C – I, D – IV
(C) A – III, B – I, C – IV, D – II (D) A – IV, B – III, C – II, D – I

7. नीचे दिए गए वंशावली चार्ट में दर्शाए गए आनुवंशिक विकार के संवर्ग की पहचान कीजिए :

1

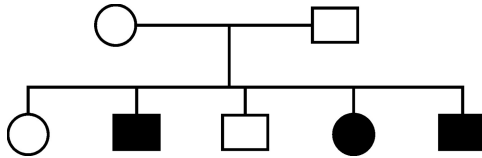

- (A) X – सहलग्न अप्रभावी (B) X – सहलग्न प्रभावी
(C) अलिंगसूत्री अप्रभावी (D) अलिंगसूत्री प्रभावी

8. 'एलीसा' (ELISA) तकनीक इस सिद्धांत पर आधारित है –

1

- (A) डीएनए प्रतिकृतीयन (B) प्रतिजन-प्रतिपिंड अन्योन्यक्रिया
(C) रोगजनक-प्रतिजन अन्योन्यक्रिया (D) प्रतिजन-प्रोटीन अन्योन्यक्रिया

9. समजात अंग इंगित करते हैं

1

- (A) अभिसारी विकास (B) अपसारी विकास
(C) अनुकूली विकिरण (D) प्राकृतिक वरण

10. 'आण्विक कैची' किस संवर्ग में आते हैं ?

1

- (A) विखंडन (क्लीविंग) एंजाइम (B) एंडोन्यूक्लिज
(C) एक्सोन्यूक्लिज (D) प्रतिबंधन एंजाइम

11. मानव के किस गुणसूत्र (क्रोमोसोम) में जीनों की संख्या न्यूनतम होती है ?

1

- (A) 21वाँ गुणसूत्र (क्रोमोसोम) (B) 16वाँ गुणसूत्र (क्रोमोसोम)
(C) 'X'- गुणसूत्र (क्रोमोसोम) (D) 'Y'-गुणसूत्र (क्रोमोसोम)

57/4/2/21

8





6. Study the table given below :

1

Contraceptive / Contraceptive Method	Mode of Action
A. The pill	I. Prevent sperm reaching cervix
B. Condom	II. Prevent implantation
C. Vasectomy	III. Inhibits ovulation
D. Copper-T	IV. Semen contains no sperm

Select the option where contraceptive/contraceptive method are correctly matched with their mode of action.

- (A) A – III, B – II, C – I, D – IV (B) A – II, B – III, C – I, D – IV
(C) A – III, B – I, C – IV, D – II (D) A – IV, B – III, C – II, D – I

7. Identify the category of genetic disorder depicted in the pedigree chart given below :

1

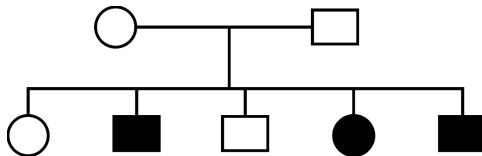

- (A) X-Linked recessive (B) X-Linked dominant
(C) Autosomal recessive (D) Autosomal dominant

8. ELISA technique is based on the principle of

1

- (A) DNA replication
(B) antigen-antibody interaction
(C) pathogen – antigen interaction
(D) antigen – protein interaction

9. Homologous organs indicate

1

- (A) Convergent evolution
(B) Divergent evolution
(C) Adaptive radiation
(D) Natural selection

10. The ‘molecular scissors’ fall in the category of :

1

- (A) Cleaving enzyme (B) Endonuclease
(C) Exonuclease (D) Restriction enzymes

11. Which of the chromosome in a human possesses the least number of genes ?

1

- (A) 21st chromosome (B) 16th chromosome
(C) X-chromosome (D) Y-chromosome

57/4/2/21

9



P.T.O.





12. नीचे स्तम्भ-‘A’ में वाणिज्यिक महत्व के कुछ उत्पादों की सूची दी गई है, जबकि स्तम्भ-‘B’ में उनके स्रोत जीवों के नाम दिए गए हैं :

स्तम्भ-A	स्तम्भ-B
जैव-सक्रिय उत्पाद	स्रोत जीव
A. साइक्लोस्पोरिन-ए	(i) स्टैप्टोकोकस
B. स्टैटिन	(ii) ट्राइकोडर्मा पॉलीस्पोरम
C. स्टैप्टोकाइनेज	(iii) पेनिसिलियम नोटेटम
D. पेनिसिलिन	(iv) मोनॉस्कस परप्थ्यूरीअस

उस विकल्प का चयन कीजिए जिसमें उत्पाद और उसके स्रोत जीव का सही मिलान किया गया है ।

- (A) A – (i), B – (ii), C – (iii), D – (iv)
 (B) A – (iii), B – (ii), C – (iv), D – (i)
 (C) A – (iv), B – (iii), C – (iv), D – (i)
 (D) A – (ii), B – (iv), C – (i), D – (iii)

1

प्रश्न संख्या 13 से 16 के लिए दो कथन दिए गए हैं – जिसमें एक को अभिकथन (A) तथा दूसरे को कारण (R) द्वारा अंकित किया गया है । इन प्रश्नों के सही उत्तर नीचे दिए गए कोडों (A), (B), (C) और (D) में से चुनकर दीजिए :

- (A) अभिकथन (A) और कारण (R) दोनों सही हैं और कारण (R), अभिकथन (A) की सही व्याख्या करता है ।
 (B) अभिकथन (A) और कारण (R) दोनों सही हैं, परन्तु कारण (R), अभिकथन (A) की सही व्याख्या नहीं करता है ।
 (C) अभिकथन (A) सही है, परन्तु कारण (R) गलत है ।
 (D) अभिकथन (A) गलत है, परन्तु कारण (R) सही है ।

13. **अभिकथन (A) :** प्लाज्मिड स्वतः प्रतिकृति बनाने वाले गोलाकार अतिरिक्त क्रोमोसोमी डीएनए हैं । 1
कारण (R) : प्लाज्मिड आमतौर पर सुकेन्द्री कोशिकाओं में पाए जाते हैं ।

14. **अभिकथन (A) :** सरकार आविष्कारकों को उनकी खोज (आविष्कार) का एकस्व (पेटेंट) प्रदान करती है । 1
कारण (R) : एकस्व (पेटेंट) किसी आविष्कार का अन्य व्यक्तियों द्वारा वाणिज्यिक उपयोग करने से रोकता है ।

15. **अभिकथन (A) :** अंजीर की एक जाति केवल ‘विशेष साथी’ बर् द्वारा ही परागित हो सकती है । 1
कारण (R) : बर् समुचित अंडनिक्षेपण स्थल की खोज करते हुए अंजीर पुष्पक्रम को परागित करती है ।

16. **अभिकथन (A) :** कुछ जलीय पारिस्थितिक-तंत्रों में जैव मात्रा का पिरैमिड उलटा होता है । 1
कारण (R) : उच्च पोषण स्तर के जीवों को अधिक ऊर्जा की आवश्यकता होती है ।





12. Given below is a list of some commercially important products in column A, whereas in column B are names of source organisms :

Column – A	Column – B
Bioactive Products	Source Organisms
A. Cyclosporin – A	(i) <i>Streptococcus</i>
B. Statins	(ii) <i>Trichoderma polysporum</i>
C. Streptokinase	(iii) <i>Penicillium notatum</i>
D. Penicillin	(iv) <i>Monascus purpureus</i>

Select the option where the product and their source organisms are correctly matched.

- (A) A – (i), B – (ii), C – (iii), D – (iv)
(B) A – (iii), B – (ii), C – (iv), D – (i)
(C) A – (iv), B – (iii), C – (iv), D – (i)
(D) A – (ii), B – (iv), C – (i), D – (iii)

1

Question Nos. 13 to 16 consist of two statements – Assertion (A) and Reason (R). Answer these questions selecting the appropriate option given below :

- (A) Both (A) and (R) are true and (R) is the correct explanation of (A).
(B) Both (A) and (R) are true and (R) is not the correct explanation of (A).
(C) (A) is true, but (R) is false.
(D) (A) is false, but (R) is true.
13. **Assertion (A)** : Plasmids are autonomously replicating circular extra-chromosomal DNA. 1
Reason (R) : Plasmids are usually present in Eukaryotic cells.
14. **Assertion (A)** : Patents are granted by government to an inventor. 1
Reason (R) : Patents prevents others from commercial use of an invention.
15. **Assertion (A)** : A given fig species can be pollinated only by its partner' wasp. 1
Reason (R) : The wasp pollinates the fig inflorescence while searching for suitable egg laying sites.
16. **Assertion (A)** : Some aquatic ecosystems have inverted biomass pyramids. 1
Reason (R) : More energy is required by the organisms occupying higher trophic levels.





खण्ड – ख

17. एआरटी में कृत्रिम वीर्यसेचन क्या है ? किन परिस्थितियों में किसी व्यक्ति को इसके लिए चिकित्सीय परामर्श दिया जाता है ? 2
18. एडीए की कमी वाले रोगी को आनुवंशिकतः निर्मित लसीकाणुओं का निवेशन बार-बार क्यों करना पड़ता है ? इसके लिए संभावित एक स्थाई उपचार का सुझाव दीजिए । 2
19. नीचे दिए गए ग्राफ का अध्ययन कीजिए जिसमें स्त्री 'X' तथा स्त्री 'Y' की एक माह की अवधि में गर्भाशयी भित्ति की मोटाई में होने वाले परिवर्तनों का निरूपण किया गया है :

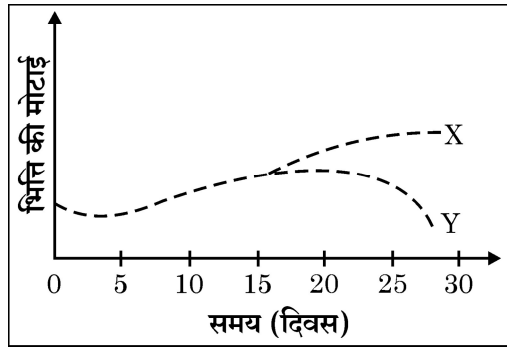

- स्त्री 'X' तथा स्त्री 'Y' के संदर्भ में ग्राफ क्या इंगित करता है ? समुचित कारण दीजिए । 2
20. (a) जैव-विविधता हॉट-स्पॉट क्षेत्र पृथ्वी के स्थलक्षेत्र के 2% से भी कम है, इन क्षेत्रों की विशेष सुरक्षा के द्वारा विलोपन की दर को कम किया जा सकता है । व्याख्या कीजिए ।
(b) भारत में किन्हीं दो हॉट-स्पॉट के नाम लिखिए । 2
21. (a) चारण खाद्य शृंखला तथा अपरद खाद्य शृंखला में अंतर स्थापित कीजिए । 2
- अथवा**
- (b) एक समुचित उदाहरण की सहायता से अंड परजीविता (ब्रूड पैरासीटिज्म) की व्याख्या कीजिए । 2

खण्ड – ग

22. पुष्प के रंग के संदर्भ में दो स्वतंत्र क्रॉस (संकरण) किए गए, एक क्रॉस तद्रूप-प्रजनन-सम मटर के पौधों के बीच तथा दूसरा क्रॉस तद्रूप-प्रजनन-सम एंटीराइनम के पौधों के बीच कराया गया । उनकी F_1 पीढ़ी की संतति के लक्षणप्ररूप लिखिए । समुचित कारण देते हुए अपने उत्तर की पुष्टि कीजिए । 3
23. एक आवृतबीजी के नर युग्मकोद्भिद/लघुबीजाणु के आरेखीय काट का चित्र बनाइए तथा इसके किन्हीं चार भागों को नामांकित कीजिए । इसके किन्हीं दो भागों के कार्य लिखिए । 3





SECTION – B

17. What is artificial insemination in ART ? Under what conditions is the person medically advised to go for it ? 2
18. Why does a patient of ADA – deficiency require repeated infusions of genetically engineered lymphocytes ? Suggest a possible permanent remedy. 2
19. Study the graph given below that represents the changes in the thickening of the uterine wall in women 'X' and women 'Y' over a period of one month :

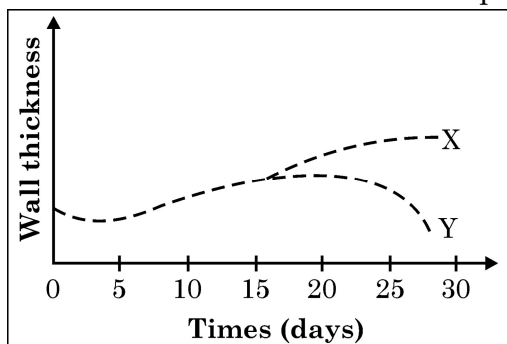

- What does the graph with respect to woman 'X' and woman 'Y' indicate ? Give suitable reason. 2
20. (a) Biodiversity hotspots cover less than 2% of Earth's land area. Strict protection of these areas can reduce the rate of ongoing extinctions. Explain. 2
- (b) Name any two hotspots in India. 2
21. (a) Differentiate between grazing food chain and detritus food chain. 2
- OR**
- (b) Explain Brood parasitism with the help of a suitable example. 2

SECTION – C

22. With reference to flower colour two independent crosses were made, one between true breeding garden pea plants and another between true breeding *Antirrhinum* plants. Write the phenotypes of their F₁-progeny. Justify your answer giving reason. 3
23. Draw a well labelled diagram of sectional view of male gametophyte/microspore of an angiosperm and write the functions of any two parts labelled. (Any four labels). 3





24. (a) (i) ड्रग के उस समूह का नाम लिखिए जिसकी आण्विक संरचना नीचे दर्शाई गई है :

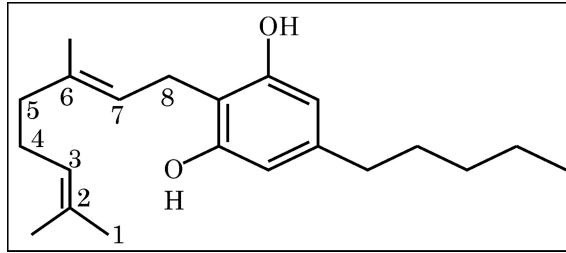

(ii) इन ड्रग्स का सेवन किस प्रकार किया जाता है ?

(iii) इन ड्रगों के सेवन से मानव शरीर का कौन सा अंग प्रभावित होता है ?

3 × 1 = 3

अथवा

(b) प्रतिरक्षी अणु की संरचना का आरेखित चित्र बनाकर किन्हीं चार भागों को नामांकित कीजिए। उनकी रासायनिक प्रकृति का उल्लेख कीजिए। उनका निर्माण करने वाली कोशिकाओं के नाम लिखिए। 3

25. निम्नलिखित में पारजीवी जन्तुओं की भूमिका का उल्लेख कीजिए :

(a) जैविक उत्पाद के निर्माण में

(b) रोगों के अध्ययन में

(c) रासायनिक सुरक्षा परीक्षण में

3

26.

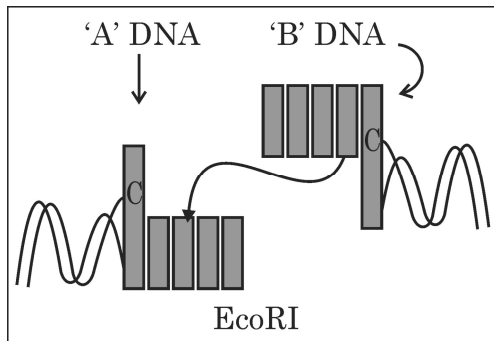

उपरोक्त व्यवस्थात्मक निरूपण में दो डीएनए खंडों को जुड़ते हुए दर्शाया गया है।

(a) खंड 'A' तथा खंड 'B' के नाम लिखिए।

1

(b) ईकोआरI (EcoRI) द्वारा पहचाने गए "पैलिन्ड्रोम" को लिखिए।

1

(c) ईकोआरI पैलिन्ड्रोम को किस स्थल पर काटता है। इसके उपरान्त पुनर्योगज डीएनए के निर्माण हेतु होने वाली परिघटनाओं का वर्णन कीजिए।

1

57/4/2/21

14





24. (a) (i) Name the group of drugs whose skeletal molecule is shown below :

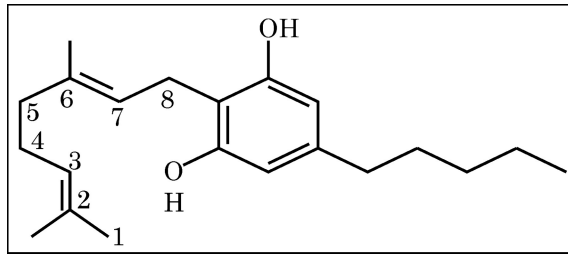

(ii) How are such drugs consumed ?

(iii) Name the human body organ affected by the consumption of these drugs. 3 × 1 = 3

OR

(b) Draw a schematic diagram of an antibody molecule and label any 4 parts. Mention their chemical nature. Name the cells which produce them. 3

25. Explain the role of transgenic animals in :

(a) Production of Biological products

(b) Studying diseases

(c) Chemical safety testing 3

26.

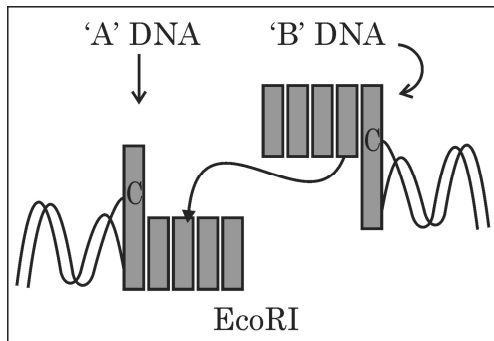

The schematic representation as above is showing the linking of two DNA fragments.

(a) Name 'A' and 'B' fragments. 1

(b) Write the 'palindrom' recognised by EcoRI. 1

(c) Where does EcoRI cut the palindrom ? Write the events followed thereafter to form a recombinant DNA. 1

57/4/2/21

15



P.T.O.





27. निम्नलिखित जीव जैव-उर्वरक के रूप में किस प्रकार कार्य करते हैं ? व्याख्या कीजिए ।

- (a) माइक्रोराइजा
- (b) ऐनाबीना
- (c) राइजोबियम

3

28. (a) तीन खोपड़ियों 'A', 'B' तथा 'C' के चित्र नीचे दिए गए हैं, यह किन प्राणियों की हैं ? इनमें से कौन सी दो एक दूसरे से अधिक सदृश्य हैं ?

2

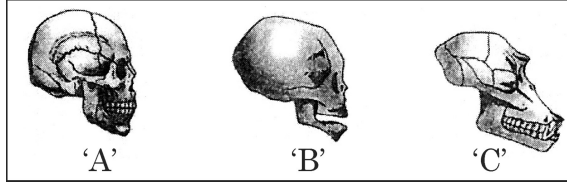

- (b) 1.5 मिलियन पूर्व पाए जाने वाले (i) वनमानुष (ऐप) सदृश्य (ii) मानव सदृश्य नर वानरगण (प्राइमेट्स) के नाम लिखिए ।

1

खण्ड – घ (केस आधारित प्रश्न)

प्रश्न संख्या 29 तथा 30 केस आधारित प्रश्न हैं । प्रत्येक प्रश्न के 3 उपप्रश्न हैं जिसके एक उपप्रश्न में आंतरिक विकल्प दिया गया है ।

29. सामान्यतः सुकेन्द्रकी कोशिकाओं में डीएनए अणु के अनुदिश एक अनुलेखन इकाई की औसत लंबाई 8,000 न्यूक्लियोटाइड्स होती है, अतः अनुलेखन से बनने वाले आरएनए की लंबाई भी इतनी ही होती है । परन्तु उपरोक्त आरएनए से औसत आकार के 400 पॉलीपेप्टाइड अमीनो अम्ल के रूपांतरण के लिए यह केवल लगभग 1200 न्यूक्लियोटाइड्स ही लेता है ।

- (a) डीएनए से अनुलेखित होने वाले आरएनए उत्पाद का नाम लिखिए जो अंततः 400 पॉलीपेप्टाइड्स वाले अमीनो अम्ल का रूपांतरण (स्थानांतरण) करता है । डीएनए से इस प्रकार के आरएनए के अनुलेखन के लिए उत्तरदायी एंजाइम का नाम लिखिए ।
- (b) उस प्रक्रम का नाम लिखकर व्याख्या कीजिए जिसके द्वारा 8000 न्यूक्लियोटाइड्स वाले डीएनए से अनुलेखित होने वाला संशोधित आरएनए का निर्माण होता है जो 400 अमीनो अम्ल वाली पॉलीपेप्टाइड का रूपांतरण (स्थानांतरण) करता है ।

1

2

57/4/2/21

16





27. How do the following organisms act as bio-fertilisers ? Explain.

- (a) *Mycorrhiza*
- (b) *Anabaena*
- (c) *Rhizobium*

3

28. (a) Whose skulls 'A', 'B', and 'C' are shown below ? Which of the two are more similar to each other ?

2

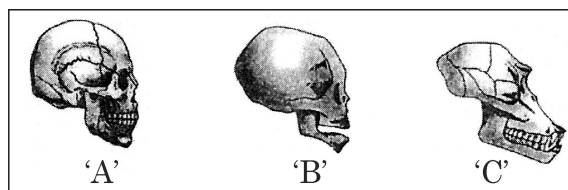

(b) Name the (i) ape like (ii) man like primates that existed 1.5 million years ago.

1

SECTION – D (Case Based Questions)

Question No. 29 and 30 are case based questions. Each question has 3 sub-questions with internal choice in one sub-question.

29. Generally, in eukaryotic cells the average length of a transcription unit along a DNA molecule is about 8,000 nucleotides, so the RNA product of the transcription is also that long. But it only takes about 1200 nucleotides from the above RNA product to translate average sized polypeptide of 400 Amino acids.

- (a) Name this RNA product transcribed from the DNA that subsequently translates into a polypeptide of 400 amino acids. Mention the enzyme responsible for transcribing this type of RNA from the DNA. 1
- (b) Name and explain the process the RNA molecule transcribed from 8000 nucleotide long DNA undergoes to be able to translate a polypeptide of 400 amino acids. 2

57/4/2/21

17



P.T.O.



- (c) प्रोकैरिओट्स (असीमकेंद्री) तथा यूकैरिओट्स (सुकेन्द्री) में DNA अनुलेखन प्रक्रम में शामिल आरएनए पॉलीमेरेजों की संख्या लिखिए । 1

अथवा

- (c) एक असीमकेंद्री तथा सुकेन्द्री कोशिका में अनुलेखन स्थल में अन्तर का उल्लेख कीजिए । 1

30. निम्नलिखित परिच्छेद को पढ़िए :

समष्टियाँ जिस आवास में रहती हैं उसमें अपनी जनन योग्यता को अधिकतम बनाने के लिए विकसित होती हैं । पारिस्थितिकविज्ञों का सुझाव है कि जीवों के जीवन-वृत्त उनके आवास जिसमें वह रहते हैं के अजीवीय तथा जीवीय घटकों द्वारा लगाए गए प्रतिबंधों के संदर्भ में विकसित होते हैं । यह मानव सहित सभी समष्टियों के वृद्धि प्रतिरूप (पैटर्न) में परिलक्षित होता है ।

नीचे ग्राफ में दिए गए समष्टि वृद्धि वक्रों का अध्ययन करके अग्रगामी प्रश्न के उत्तर लिखिए :

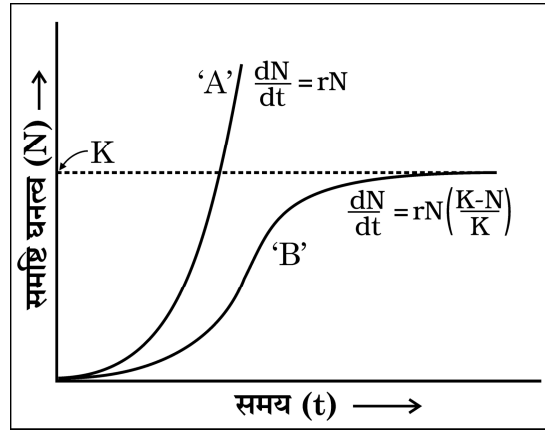

- (a) वृद्धि वक्र 'A' तथा 'B' को पहचानिए । 1
(b) उल्लेख कीजिए कि ग्राफ में बिन्दु रेखा क्या इंगित करती है तथा इसका महत्त्व भी बताइए । 1

अथवा

- (b) वृद्धि वक्र 'A' की अपेक्षा वृद्धि वक्र 'B' अलग प्रतिरूप दर्शाता है । समुचित कारण द्वारा कथन की न्यायसंगतता सिद्ध कीजिए । 1
(c) (i) दोनों में से कौन सा वक्र अधिक “वास्तविक (यथार्थ)” है और क्यों ?
(ii) हमारे देश में मानव समष्टि (जनसंख्या) के संदर्भ में दोनों में से कौन सा वक्र वर्तमान समय में अधिक प्रासंगिक है और क्यों ? 1 + 1





- (c) Write the number of RNA polymerases involved in the transcription of DNA in a prokaryote and eukaryotes. 1

OR

- (c) Mention the difference in the site of transcription in a prokaryote and eukaryote cell. 1

30. Read the following passage :

Populations evolve to maximise their reproductive fitness in the habitat in which they live. Ecologists suggest, the life history of organisms have evolved in relations to the constraints imposed by the biotic and abiotic components of the habitat in which they live. This gets reflected in the population growth pattern of all organisms including humans.

Study the population growth curves shown in the given graph and answer the questions that follow :

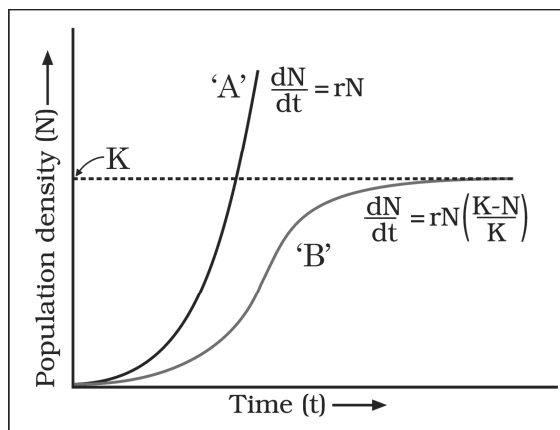

- (a) Identify the growth curves 'A' and 'B'. 1
- (b) Mention what does the dotted line in the graph indicate and state its importance also. 1

OR

- (b) Growth curve 'B' shows a different pattern from that of growth curve 'A'. Justify giving one reason. 1
- (c) (i) Which one of the two curves is more "realistic" and why ?
- (ii) Which one of the two curves is relevant in present days with respect to human population in our country and why ? 1 + 1

57/4/2/21

19



P.T.O.



खण्ड – ड

31. (a) (i) किसी स्त्री (मानव मादा) के आर्तव चक्र में निम्नलिखित प्रावस्थाओं की व्याख्या कीजिए :
(1) ऋतुस्राव/रजोदर्शन
(2) पुटकीय प्रावस्था
(3) स्रावी प्रावस्था 3
- (ii) 'आर्तव चक्र की सही समझ (जानकारी) परिवार नियोजन के लिए अत्यधिक सहायक हो सकती है।' क्या आप इस कथन से सहमत हैं ? अपने उत्तर के समर्थन में समुचित कारण लिखिए। 2

अथवा

- (b) (i) आवृत्तबीजियों में भ्रूण के विकास से पहले भ्रूणपोष का विकास क्यों होता है ? परिपक्व एल्बुमिनस बीजों में भ्रूणपोष की भूमिका का वर्णन कीजिए। 2
- (ii) एक द्विबीजपत्री में भ्रूण के विकास के विभिन्न चरणों को भ्रूण के पूर्णतः परिपक्व होने तक की अवस्थाओं का नामांकित चित्र बनाइए। 3
32. (a) एचआईवी के मानव शरीर में प्रविष्ट होने के समय से लेकर उसके पूर्णरूपेण एड्स में बदल जाने तक के जीवन चक्र का वर्णन कीजिए। 5

अथवा

- (b) (i) मानव में मलेरिया रोग के अभिलक्षण लिखिए तथा व्याख्या कीजिए कि यह अभिलक्षण किसके कारण उत्पन्न होते हैं ? 2½
- (ii) मलेरियाई परजीवी के जीवन चक्र की लैंगिक अवस्थाओं के प्रारंभ होने से उसके पूर्ण होने तक के चरणों का वर्णन कीजिए जब तक वह नए चक्र प्रारंभ करने के लिए तैयार होता है। 2½
33. (a) नीचे दिए गए योजनात्मक आरेख का अध्ययन करके आगे दिए गए प्रश्नों के उत्तर लिखिए :

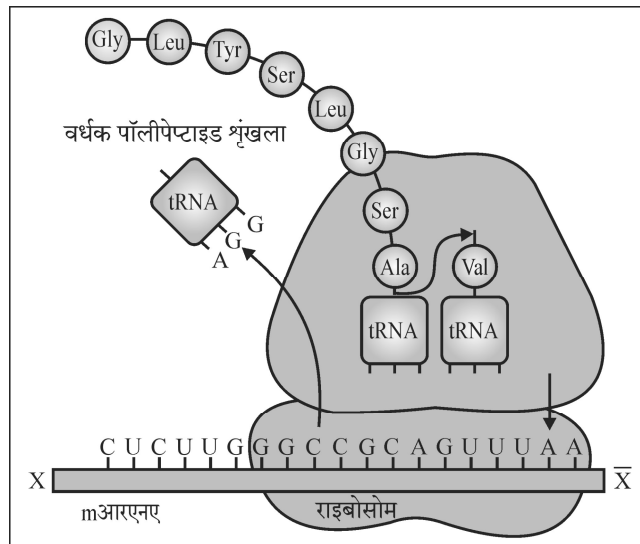



SECTION – E

31. (a) (i) Explain the following phases in the menstrual cycle of a human female :
(1) Menstruation
(2) Follicular phase
(3) Luteal phase **3**
- (ii) 'A proper understanding of the menstrual cycle can help immensely in family planning.' Do you agree with the statement ? Provide reasons for your answer. **2**

OR

- (b) (i) Why does endosperm development precede embryo development in angiosperm seeds ? State the role of endosperm in mature albuminous seeds. **2**
- (ii) Draw a labelled diagram showing the different embryonic stages of a dicot plant, upto a fully mature embryo. **3**
32. (a) Describe the life cycle of HIV from the time of its entry into the human body till full blown AIDS sets in. **5**

OR

- (b) (i) Write the symptoms of malaria in human and explain what causes these symptoms. **2½**
- (ii) Describe the different steps in the sexual mode of reproduction in the life cycle of a malarial parasite from the time of its initiation till where it is completed and ready to start a fresh cycle. **2½**
33. (a) Study the schematic diagram given below and answer the questions that follow :

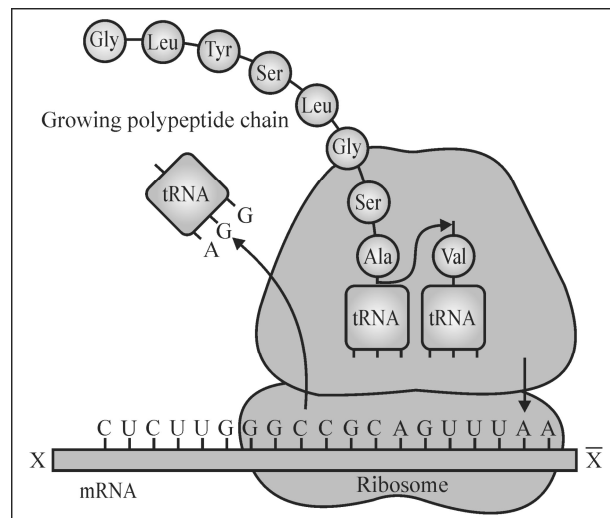

57/4/2/21

21



P.T.O.



- (i) दर्शाए गए mआरएनए खंड में 'X' से 'X̄' की ध्रुवणता को पहचानिए । उल्लेख कीजिए कि रूपांतरण के दौरान पॉलीपेप्टाइड शृंखला में और कितने अमीनो अम्ल जोड़े जा सकते हैं और क्यों । 1½
- (ii) रूपांतरण (स्थानांतरण) के लिए प्रारंभक प्रकूट, इसका प्रतिप्रकूट (एंटीकोडान) तथा इसके अमीनो अम्ल का नाम लिखिए जिसको यह कोड करता है । 1½
- (iii) अनुकूलक अणु के आवेशीकरण की व्याख्या कीजिए । इस अणु को आवेशित करने की आवश्यकता क्यों होती है ? 2

अथवा

- (b) (i) मानव रक्त विकार 'दात्र कोशिका अरक्तता (सिकल सेल एनीमिया) को यह नाम क्यों दिया गया है ? 1
- (ii) इस विकार की अभिव्यक्ति के आनुवंशिक आधार की व्याख्या कीजिए । 2
- (iii) एक क्रॉस बनाकर समझाइए कि सामान्य जनकों (युगल) से दात्र कोशिका अरक्तता (सिकल सेल एनीमिया) वाला बच्चा (संतति) किस प्रकार पैदा हो सकता है । 2





- (i) Identify the polarity from 'X' to ' \bar{X} ' in the mRNA segment shown. Mention how many more amino acids can be added to the polypeptide that is being translated and why. 1½
- (ii) Write the initiating codon for translation, its anticodon and the amino acid it codes for. 1½
- (iii) Explain the charging of an adaptor molecule. Why this molecule needs to be charged ? 2

OR

- (b) (i) Why is sickle-cell anaemia, a human blood disorder so named ? 1
- (ii) Explain the genetic basis that results in the expression of this disorder. 2
- (iii) Work out a cross to explain how normal parents may have a sickle-cell anaemic child. 2
-





57/4/2/21

228 B

24



Marking Scheme

Strictly Confidential

(For Internal and Restricted use only)

Senior Secondary School Certificate Examination, 2024

SUBJECT NAME BIOLOGY (Q.P. CODE 57/4/2)

General Instructions: -

1	You are aware that evaluation is the most important process in the actual and correct assessment of the candidates. A small mistake in evaluation may lead to serious problems which may affect the future of the candidates, education system and teaching profession. To avoid mistakes, it is requested that before starting evaluation, you must read and understand the spot evaluation guidelines carefully.
2	“Evaluation policy is a confidential policy as it is related to the confidentiality of the examinations conducted, Evaluation done and several other aspects. Its’ leakage to public in any manner could lead to derailment of the examination system and affect the life and future of millions of candidates. Sharing this policy/document to anyone, publishing in any magazine and printing in News Paper/Website etc may invite action under various rules of the Board and IPC.”
3	Evaluation is to be done as per instructions provided in the Marking Scheme. It should not be done according to one’s own interpretation or any other consideration. Marking Scheme should be strictly adhered to and religiously followed. However, while evaluating, answers which are based on latest information or knowledge and/or are innovative, they may be assessed for their correctness otherwise and due marks be awarded to them. In class-XII, while evaluating two competency-based questions, please try to understand given answer and even if reply is not from marking scheme but correct competency is enumerated by the candidate, due marks should be awarded.
4	The Marking scheme carries only suggested value points for the answers These are in the nature of Guidelines only and do not constitute the complete answer. The students can have their own expression and if the expression is correct, the due marks should be awarded accordingly.
5	The Head-Examiner must go through the first five answer books evaluated by each evaluator on the first day, to ensure that evaluation has been carried out as per the instructions given in the Marking Scheme. If there is any variation, the same should be zero after deliberation and discussion. The remaining answer books meant for evaluation shall be given only after ensuring that there is no significant variation in the marking of individual evaluators.
6	Evaluators will mark(√) wherever answer is correct. For wrong answer CROSS ‘X’ be marked. Evaluators will not put right (✓) while evaluating which gives an impression that answer is correct and no marks are awarded. This is most common mistake which evaluators are committing.



7	If a question has parts, please award marks on the right-hand side for each part. Marks awarded for different parts of the question should then be totaled up and written in the left-hand margin and encircled. This may be followed strictly.
8	If a question does not have any parts, marks must be awarded in the left-hand margin and encircled. This may also be followed strictly.
9	If a student has attempted an extra question, answer of the question deserving more marks should be retained and the other answer scored out with a note “Extra Question” .
10	No marks to be deducted for the cumulative effect of an error. It should be penalized only once.
11	A full scale of marks 70 has to be used. Please do not hesitate to award full marks if the answer deserves it.
12	Every examiner has to necessarily do evaluation work for full working hours i.e., 8 hours every day and evaluate 20 answer books per day in main subjects and 25 answer books per day in other subjects (Details are given in Spot Guidelines). This is in view of the reduced syllabus and number of questions in question paper.
13	Ensure that you do not make the following common types of errors committed by the Examiner in the past:- <ul style="list-style-type: none"> ● Leaving answer or part thereof unassessed in an answer book. ● Giving more marks for an answer than assigned to it. ● Wrong totaling of marks awarded on an answer. ● Wrong transfer of marks from the inside pages of the answer book to the title page. ● Wrong question wise totaling on the title page. ● Wrong totaling of marks of the two columns on the title page. ● Wrong grand total. ● Marks in words and figures not tallying/not same. ● Wrong transfer of marks from the answer book to online award list. ● Answers marked as correct, but marks not awarded. (Ensure that the right tick mark is correctly and clearly indicated. It should merely be a line. Same is with the X for incorrect answer.) ● Half or a part of answer marked correct and the rest as wrong, but no marks awarded.
14	While evaluating the answer books if the answer is found to be totally incorrect, it should be marked as cross (X) and awarded zero (0) Marks.
15	Any unassessed portion, non-carrying over of marks to the title page, or totaling error detected by the candidate shall damage the prestige of all the personnel engaged in the evaluation work as also of the Board. Hence, in order to uphold the prestige of all concerned, it is again reiterated that the instructions be followed meticulously and judiciously.
16	The Examiners should acquaint themselves with the guidelines given in the “Guidelines for Spot Evaluation” before starting the actual evaluation.
17	Every Examiner shall also ensure that all the answers are evaluated, marks carried over to the title page, correctly totaled and written in figures and words.
18	The candidates are entitled to obtain photocopy of the Answer Book on request on payment of the prescribed processing fee. All Examiners/Additional Head Examiners/Head Examiners are once again reminded that they must ensure that evaluation is carried out strictly as per value points for each answer as given in the Marking Scheme.



MARKING SCHEME
Senior Secondary School Examination, 2024
BIOLOGY (Subject Code-044)
[Paper Code: 57/4/2]

SECTION-A			
1.	(A)/ antipodal, zygote and endosperm	1	1
2.	(A)/ Aneuploidy	1	1
3.	(D)/ P – Transcription, Q – mRNA, R – Translation	1	1
4.	(A)/ A – connective, B – Endothecium, C – Pollen grain	1	1
5.	(C)/ Ovum - A, Morula - E, Blastocyst - G	1	1
6.	(C)/ A - III, B - I, C - IV, D - II	1	1
7.	(C)/ Autosomal Recessive	1	1
8.	(B)/ Antigen- Antibody interaction	1	1
9.	(B)/ Divergent evolution	1	1
10.	(D)/ Restriction Enzymes	1	1
11.	(D)/ Y chromosomes	1	1
12.	(D)/ A - (ii), B - (iv), C – (i), D – (iii)	1	1
13.	(C)/ (A) is true, but (R) is false.	1	1
14.	(A)/ Both Assertion (A) and Reason (R) are true and Reason (R) is the correct explanation of Assertion (A).	1	1
15.	(A)/ Both Assertion (A) and Reason (R) are true and Reason (R) is correct explanation of Assertion (A).	1	1
16.	(B)/ Both Assertion (A) and Reason (R) are true and Reason (R) is not correct explanation of Assertion (A).	1	1
SECTION - B			
17.	<ul style="list-style-type: none"> • Artificial insemination refers to the transfer of semen collected from the husband or male donor into the vagina or into the uterus of the female. It is medically advised when: <ul style="list-style-type: none"> (i) The male partner is unable to inseminate the female. (ii) The sperm count is low in the ejaculate. 	1 ½ ½	2
18.	<ul style="list-style-type: none"> • The genetically – engineered lymphocytes have a limited life span or are mortal hence the patient requires periodic infusion of genetically engineered lymphocytes. • There could be a permanent cure if the gene isolated from bone marrow cells producing ADA is introduced into the cells at early embryonic stage. 	1 1	2
19.	<ul style="list-style-type: none"> • X- In woman X thickness of uterine wall increases after mid of menstrual cycle; Reason- due to fertilization of egg/pregnancy/conceived 	½+½	

	<ul style="list-style-type: none"> Y- In woman Y thickness of uterine wall decreases after mid of menstrual cycle ; Reason- egg has not been fertilized/leading to the breakdown of lining of the uterus/menstrual flow/ bleeding. 	$\frac{1}{2}+\frac{1}{2}$	2												
20.	<p>(a) Biodiversity hotspots are the regions with very high level of species richness, and high degree of endemism</p> <p>(b) Western Ghats, The Himalayas, Indo – Burma region (Any two)</p>	$\frac{1}{2}+\frac{1}{2}$	2												
21.	<p>(a)</p> <table border="1" style="width: 100%; border-collapse: collapse;"> <thead> <tr> <th style="width: 10%;"></th> <th style="width: 45%; text-align: center;">Grazing Food Chain</th> <th style="width: 45%; text-align: center;">Detritus Food Chain</th> </tr> </thead> <tbody> <tr> <td style="text-align: center;">1.</td> <td>It starts with producers.</td> <td>Starts from dead organic matter/ detritus</td> </tr> <tr> <td style="text-align: center;">2.</td> <td>2nd trophic level is occupied by herbivores.</td> <td>2nd trophic level is occupied by detritivores.</td> </tr> <tr> <td style="text-align: center;">3.</td> <td>In aquatic ecosystem a major fraction of energy flows through this type of food chain</td> <td>In terrestrial ecosystem much larger fraction of energy flow through such type of food chain</td> </tr> </tbody> </table> <p style="text-align: center;">(Any two corresponding points points)</p> <p style="text-align: center;">OR</p> <p>(b)</p> <ul style="list-style-type: none"> Brood parasitism is a method of parasitism in which the parasitic bird lays its eggs in the nest of the host bird and let the host bird to incubate them. Example – The cuckoo bird lays its eggs in the nest of crow, egg of cuckoo bird resembles crows' egg in size and colour to reduce the chance of host bird detecting and ejecting them from nest 		Grazing Food Chain	Detritus Food Chain	1.	It starts with producers.	Starts from dead organic matter/ detritus	2.	2 nd trophic level is occupied by herbivores.	2 nd trophic level is occupied by detritivores.	3.	In aquatic ecosystem a major fraction of energy flows through this type of food chain	In terrestrial ecosystem much larger fraction of energy flow through such type of food chain	1+1	1 $\frac{1}{2}+\frac{1}{2}$
	Grazing Food Chain	Detritus Food Chain													
1.	It starts with producers.	Starts from dead organic matter/ detritus													
2.	2 nd trophic level is occupied by herbivores.	2 nd trophic level is occupied by detritivores.													
3.	In aquatic ecosystem a major fraction of energy flows through this type of food chain	In terrestrial ecosystem much larger fraction of energy flow through such type of food chain													
			2												

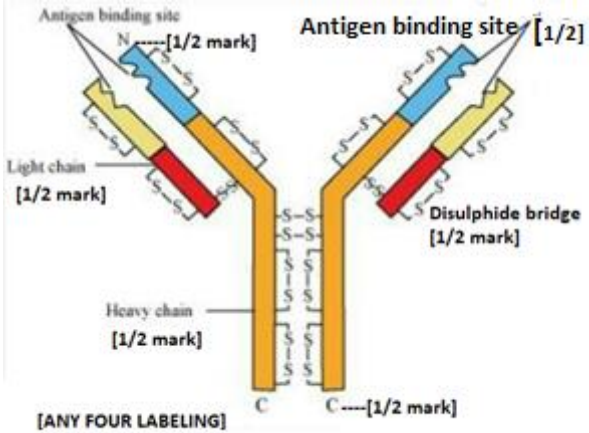

SECTION - C			
22.	<p>•</p> <p>(Violet flower) PP X (White flower) pp [1/2 mark]</p> <p>Pp (Purple flower)</p> <p>All purple flower [1/2 mark]</p> <p>It shows complete dominance. [1/2 mark]</p> <p>•</p> <p>Parents Red flower RR x White flower rr [1/2 mark]</p> <p>Rr (All pink colour flowers) [1/2 mark]</p> <p>F_1 generation</p> <p>It is a case of incomplete dominance [1/2 mark]</p>	$\frac{1}{2} \times 3$	$\frac{1}{2} \times 3$
23.	<p>[Vegetative cell, generative cell, exine, intine, germ pore]</p> <p>(Any four labeling to be considered)</p> <p>Vegetative cell- contain abundant food reserve for pollen germination</p> <p>Generative cell- Divide to produce male gametes</p> <p>Exine – Protective layer</p> <p>Intine- Involved in the formation of pollen tube.</p> <p>Germ pore- Pollen tube emerges from this point.</p> <p>[Marks to be given to two correct labeling with their respective correct function only]</p>	$\frac{1}{2} \times 4$	$\frac{1}{2} \times 2$
			3

24.	<p>(a) (i) Cannabinoids (ii) Inhalation, Oral ingestion (iii) Brain/Heart (cardiovascular system)</p> <p style="text-align: center;">OR</p> <p>(b)</p>  <p>[ANY FOUR LABELING]</p> <p>[Four labeling – Antigen binding site, Light chain, Heavy chain, C-terminal, N terminal, Disulphide bridge - ½ mark each]</p> <ul style="list-style-type: none"> • They are chemically Proteins • B- lymphocytes/B- cells 	<p>1 ½+½ 1</p> <p>½ X4</p> <p>½ ½</p>	<p>3</p>
25.	<p>(a) Production of Biological products- Human protein α-1 antitrypsin used to treat emphysema produced by transgenic organism / Transgenic cow 'Rosie' produce human protein enriched in α- lactalbumin</p> <p>(b) Studying Diseases- Transgenic models of human disease like cystic fibrosis, cancer etc. are designed to increase our understanding of how genes contribute to development of disease.</p> <p>(c) Chemical safety testing- Transgenic animals are made that carry genes which make them more sensitive to toxic substance. They are then exposed to toxic substance and the effect studied.</p>	<p>1</p> <p>1</p> <p>1</p>	<p>3</p>
26.	<p>(a)</p> <ul style="list-style-type: none"> • A– vector DNA, • B is foreign DNA/ Desired DNA/ Alien DNA <p>(b) 5' G A A T T C 3' 3' C T T A A G 5'</p>	<p>½+½</p> <p>1</p>	



	(c) It cuts the DNA between bases G and A only , It give rise to sticky ends of 'A' DNA and 'B' DNA which is joined by ligase enzyme to form recombinant DNA.	1/2+1/2	3
27.	(a) <i>Mycorrhiza</i> (Fungal symbiont of the association) Absorb phosphorus from soil and these nutrients are passed on to the host plant. (b) <i>Anabaena</i> – Fix atmospheric nitrogen and adds organic matter to the soil, thereby increasing soil fertility. (c) <i>Rhizobium</i> – Fix atmospheric nitrogen (in leguminous plants) into organic form which is used by the plant as nutrient.	1 1 1	3
28.	(a) A – Modern human being B – Baby chimpanzee C – Adult chimpanzee • Skull of baby chimpanzee is more like adult human skull (A and B) (b) (i) <i>Dryopithecus</i> (ii) <i>Ramapithecus</i>	1/2 x3 1/2 1/2+1/2	3
SECTION - D			
29.	(a) • hnRNA/ heterogeneous nuclear RNA • RNA polymerase II (b) hnRNA undergo capping at 5' end (methyl guanosine triphosphate/mGppp), and tailing at 3' end (with poly A tail or adenylate residue), further splicing is carried out, where non coding sequences or introns are removed and coding sequence or exons are joined together/ diagrammatic representation with given markers can also be considered. (c) • In prokaryotes - 1 • In eukaryotes-3 OR (c) In prokaryotes the transcription takes place in the cytoplasm/cytosol whereas in Eukaryote transcription occurs in the Nucleus,	1/2 1/2 1/2x4 1/2 1/2 1	4
30.	(a) • A- exponential growth curve/ J-shaped curve • B- Logistic growth curve/ S- shaped curve/ sigmoid curve	1/2 1/2	

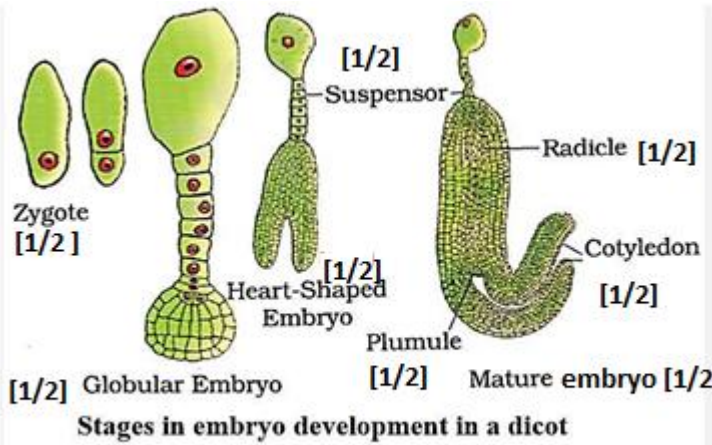

	<p>(b)</p> <ul style="list-style-type: none"> • It represents carrying capacity (K) • Maximum possible number of individuals beyond which no growth of population is observed. <p style="text-align: center;">OR</p> <p>(b) Growth curve B is formed when resources (food and space) in nature are limited have environmental checks while growth curve A is formed when resources are unlimited with no environmental checks.</p> <p>(c) (i)</p> <ul style="list-style-type: none"> • ‘B’/ Logistic growth curve • As resources are never infinite in nature. <p>(ii)</p> <ul style="list-style-type: none"> • J-shaped curve/ exponential growth <p>It is a continuous growing population.</p>	<p>½</p> <p>½</p> <p>1</p> <p>½</p> <p>½</p> <p>½</p> <p>½</p>	<p>4</p>
SECTION - E			
31.	<p>(a)</p> <p>(i)</p> <p>(1)Menstruation phase – This flow is due to breakdown of endometrium lining of uterus and blood vessels along with unfertilized ovum continues for 3-5 days. This happens when ovum is not fertilized.</p> <p>(2) Follicular phase – In this phase follicle develops into mature Graafian Follicle. This is known as proliferative phase because endometrium lining regenerates. It last for 10 days.</p> <p>(3) Luteal phase – This phase lasts for about 10-14 days. This is also known as secretory phase. In this phase corpus luteum is formed which secretes large amount of progesterone that is required for maintenance of pregnancy.</p> <p>(ii)</p> <ul style="list-style-type: none"> • Yes, • Chances of fertilization are nil if abstain from Coitus from day 10-17th day of menstrual cycle. <p style="text-align: center;">OR</p>	<p>1</p> <p>1</p> <p>1</p> <p>1</p> <p>1</p>	

	<p>(b)</p> <p>(i)</p> <ul style="list-style-type: none"> The embryo development starts only after a certain amount of endosperm is developed because it is an adaptation for assured nutrition to the developing embryo thus endosperm development precedes embryonic development To provide nutrition to the embryo. <p>(ii)</p>  <p>Stages in embryo development in a dicot [Any 6 labeling to be considered]</p>	<p>1+1</p> <p>$\frac{1}{2} \times 6$</p>	<p>5</p>
<p>32.</p>	<p>(a) HIV enters human body and enter macrophage cells , where viral RNA is introduced in the cell, Viral DNA is produced by reverse transcription, Viral DNA incorporated in host genome, New viral RNA is produced by the infected cell, New viruses are produced, which enter T-helper cells replicate and produces its progeny, Progeny viruses attack other T helper cells, this is repeated leading to progressive decline in the number T helper cells, person become immunodeficient and HIV AIDS develop./</p>	<p>$\frac{1}{2} \times 10$</p>	

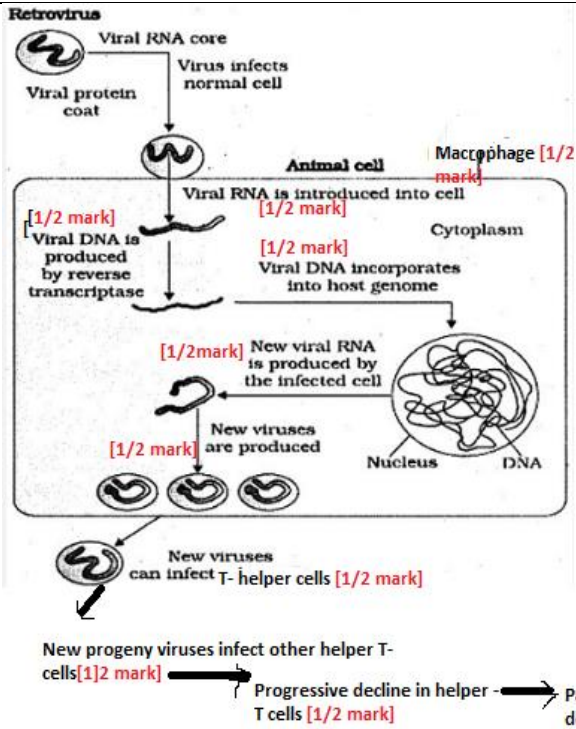

1/2x10

OR

(b)
(i)

- Chills , and high fever fever occurs in a cyclic order/every 2-3 days,
- fever is due to the toxic haemozoin,
- release at the time of RBC rupture.

1/2+1/2
1/2
1



	<p>(ii)</p> <p>Mature infective stages (sporozoites) escape from intestine and migrate to the mosquito salivary glands [1/2 mark]</p> <p>Sporozoites Salivary glands Mosquito Host</p> <p>Fertilisation and development take place in the mosquito's intestine [1/2 mark]</p> <p>[1/2 mark]</p> <p>Female mosquito takes up gametocytes with blood meal</p> <p>Gametocytes Female Male</p> <p>[1/2 mark] Sexual stages (gametocytes) develop in red blood cells</p>	1/2x5	5
33.	<p>(a)</p> <p>(i)</p> <ul style="list-style-type: none"> • X to \bar{X} is 5' \longrightarrow 3' • No more amino acids will be added • as the last codon UAA is a stop codon <p>(ii)</p> <ul style="list-style-type: none"> • AUG • Anticodon - UAC • methionine <p>(iii)</p> <ul style="list-style-type: none"> • The amino acids are activated in the presence of ATP , and linked to their cognate tRNA or the adapter molecule, • Amino acids are activated so peptide bonds can be formed using this energy. <p style="text-align: center;">OR</p>	1/2 x3 1/2 x3 1/2+1/2	1



(b)

(i) the RBC in such patients takes up a sickle shape instead of biconcave.

1

(ii) The defect is caused by the substitution of Glutamic acid (Glu) by Valine (Val), at the sixth position of the beta globin chain of the haemoglobin molecule /The substitution of amino acid in the globin protein results due to the single base substitution at the sixth codon of the beta globin gene, from GAG to GUG.

1+1

(iii)

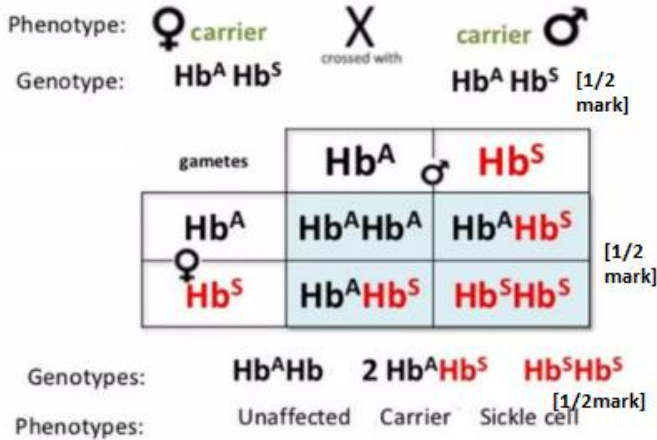

1/2 x4

It is an autosomal recessive disorder [1/2 mark]

5